

MX921 Option T45 Rear Connector Interface

INTRODUCTION

The MX921 when fitted with option T45 provides the up most flexibility in interfacing the transceiver to external peripheral equipment. The rear sockets are wired for system oriented compatibly. The T45 provides similar interface point to that of the MX800. It also provides RS 232 Communication between radio and PC from the rear. The exact functionality and available features will also depend upon the firmware version installed. Due to ongoing development please refer to www.spectraeng.com.au for updates on firmware revision.

The information provided is *not intended to replace* but rather to be used in conjunction with, existing technical manual.

Special features

- Plug and Play installation with MX921.
- TX & RX Balanced Audio.
- Audio bridge facility. For the use within link systems.
- TX Input and RX output Line level adjustments.
- Facilities to change E & M lead polarity, source/sink.
- Three Programmable Alarms outputs.
- Multiple CTCSS Decode logic output. For controlling peripherals equipment when a valid RX CTCSS TONE is decoded.
- TX Audio coupling from DC-3400Hz



SOFTWARE MENU SYSTEM

The T45 is design for plug and play when connecting to MX921. Once fitted its own internal menu system can

be accessed with any general terminal package. The menu system allows the user to change several configuration settings to suit the environment in which the MX921 must operate.

The menu system is entered through a terminal emulator program. The settings are 57600 baud, no parity, 8 data bits and 1 stop bit. HyperTerminal, which is included with Windows, is a suitable program for this purpose.

The command 'RMENU' is entered on the terminal, this command is not case sensitive. The user will then be presented with a menu system from which various settings and configurations can be selected. To exit the menu system the <ESC> key can be pressed.

HYPERTERMINAL CONNECTION

On the **File** menu, click **New Connection**.

In the **Name** box, type a name that describes the connection. (eg.MX921)

In the **Icon** box, click the appropriate icon, and then click **OK**.

In the **Connect To** dialog box, select Com port you wish to use, and then click **OK**.

Set Com port properties, (The settings are 57600 baud, no parity, 8 data bits and 1 stop bit, no hardware control) and then click **OK**.

Type "RMENU" to access the MX921

See hyper terminal help screen for further help.



INTERFACING INFORMATION

The user connections to the MX921 are all made via the rear panel where the following connectors are located.

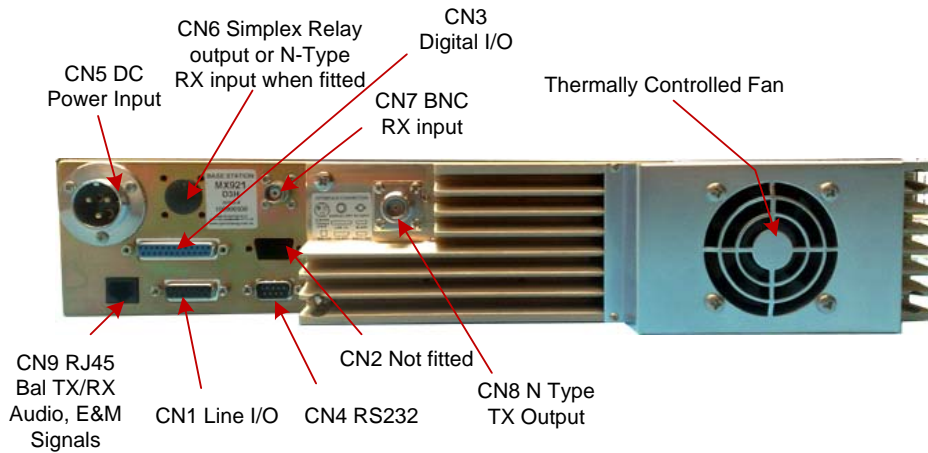

Figure 1-2 Rear view of MX921 with T45 Fitted

No	Conn Type	Function	Description
CN1	DB15-F	Line I/O	Provides the necessary analog receiver and transmitter interface for system interfacing.
CN2	DB9-F	Future Planel	Future Planel
CN3	DB25-F	Parallel I/O	Provides two 8 bit input ports, where one is used as the parallel BCD channel select. Also one 8-bit output port.
CN4	DB9-M	RS-232 serial port	9600 Baud serial port for frequency programming, channel selection and alarm and status monitoring.
CN5	3 PIN	DC Power input	13.8 Volt DC power input. Also +28 Volt input on spare pin or Solar Panel input used in conjunction with S02 Option
CN6	N TYPE	Simplex relay out or N type RX input	Location for internal simplex relay. The antenna for RX / TX connects to this point. Alternatively a N-Type connector can be used for the input to the receiver for full duplex operation
CN7	BNC	RX input	Standard BNC connector for the input to the receiver for full duplex operation.
CN8	N TYPE	TX output	The RF power output from the transmitter for full duplex operation.
CN9	RJ45	Balanced line I/O	Balanced and isolated Line TX and RX VF and isolated E & M signals

Table 1 MX921 Interface Connectors

CN1 DB15 Female Line I/O Connector

This connector provides the primary interface to the transceiver. Pin connection and function details are shown in Table 2 CN1 Connections below.

Pin no	Function
1	O/C ALARM OUTPUT #2. Open collector output sinks current to earth when an alarm condition occurs. The function of the alarm and the trip points as appropriate are programmable via the inbuilt menu system. Selectable Alarm functions are Low Fwd Power, High Refl Power, Low Supply Volts, High Supply Volts, High PA Temp, TX Unlocked and RX Unlocked.
2	+12 VOLTS DC OUTPUT. +12 Volt output to power small external devices or interfaces. Max load 500mA.
3	RECEIVER AUDIO 600Ω. Receiver audio output from op-amp. Default nominal line level is set to -10dBm. Unbalanced output with common return to analog Earth
4	RX DISCRIMINATOR. The receiver discriminator audio output is buffered, unfiltered and DC coupled to this point. Output impedance is low.
5	O/C ALARM OUTPUT #3. Open collector output sinks current to earth when an active condition occurs. The function of the alarm and the trip points as appropriate are programmable via the utility program. Selectable Alarm functions are Low Fwd Power, High Refl Power, Low Supply Volts, High Supply Volts, High PA Temp, TX Unlocked and RX Unlocked.
6	O/C ALARM OUTPUT #1 OR M-LEAD. This output is configurable via inbuilt menu system as either a qualified M-lead or an alarm output. Open collector output sinks current to earth when an alarm condition occurs. The function of the alarm and the trip points as appropriate are programmable via the utility program. Selectable Alarm functions are Low Fwd Power, High Refl Power, Low Supply Volts, High Supply Volts, High PA Temp, TX Unlocked and RX Unlocked.
7	RX RSSI OUTPUT. The receiver's received signal strength indicator voltage is proportional to the log of the signal level at the antenna input. Voltage range is 0 to 5 volts. Output impedance is low. Dynamic range > 60dB.
8	REPEATER ENABLE. On/off mode control of internal repeater function. Logic control to enable / disable repeater function. Input is pulled up to +3.3 VDC. May be driven by open collector or voltage source / sink.
9	TRANSMIT AUDIO INPUT 600Ω. Transmitter audio input to op-amps etc. Nominal line input level is -10dBm. Can handle levels between -35dBm and 0dBm. Unbalanced input with common return to analog Earth.
10	EARTH COMMON GROUND\ EARTH. General common earth for analog VF input and output.
11	I/O 5V Logic. Reserved as I/O for future Plans
12	TX PTT IN. (E-LEAD). The standard PTT input is active low and may be driven from standard +5V logic outputs or open collector
13	TX DC-FM INPUT OR WIDE BAND INPUT. Select the internal jumper JMP5 to configure this input as either the <i>DC-FM input</i> or <i>Wide Band input</i> . Remove jumper if not used.

Pin no	Function
	<p>DC-FM input (JMP5 in position 1-2)</p> <p>Audio or data may be connected to this point. In order to conform to transmitter bandwidth emissions limits, this input is hard limited to the peak deviation and Bessel filtered -3dB @ 3400Hz for minimum group delay distortion. Input impedance is >10KΩ. Input sensitivity is nominally 1Vp-p but depends. If this input is not used then jumper # JMP5 on the Micro Controller board should be removed to avoid any pickup of stray signals, or alternatively do not connect any wires to this pin. Avoid the use of ribbon cables longer than 30-50cm as this may result in excess coupling or crosstalk.</p> <p>WIDEBAND input: (JMP5 in position 2-3)</p> <p>Wide band audio or data may be connected to this point. WARNING: In order to conform to transmitter bandwidth emissions limits, the signal MUST be pre-filtered and level controlled, failure to do this WILL result in non-compliance of the TX emission spectrum. This input mode is not normally used except in special cases.</p>
14	<p>RX MUTE / SQUELCH MONITOR. The RF mute status may be monitored by reading this voltage. +5volt logic signal indicates mute status. This output is not CTCSS dependent. Output impedance approx 100Ω. The polarity is selectable via the internal menu system.</p>
15	<p>RECEIVER AUDIO 600Ω. Receiver audio output from op-amp. Default nominal line level is set to -10dBm. Unbalanced output with common return to analog Earth.</p>

Table 2 CN1 Connections

CN3 DB25 Female Digital I/O Connector

Each CMOS logic input is protected by a 10K Ohm series resistor to the input of the logic chip. There is also a 10K Ohm pull resistor at each input. Each logic output is protected by a 1K-Ohm series resistor from the output of the logic chip. This feature is currently under development please refer to www.spectraeng.com.au for updates on firmware revision.

The Digital output port can be configured to indicate a binary bit pattern when using a multiple CTCSS Tone. For example when a valid decode of CTCSS Tone is received, the option board will then reflect the appropriate binary pattern which it is associated within the multiple CTCSS table. The multiple CTCSS table is program via the inbuilt menu system.

Pin No	Function
13	DIGITAL EARTH.
25	INPUT PORT A. 8-bit Logic Input bit 0. (Power control bit 0)
12	INPUT PORT A. 8-bit Logic Input bit 1. (Power control bit 1)
24	INPUT PORT A. 8-bit Logic Input bit 2. (RX CTCSS control)
11	INPUT PORT A. 8-bit Logic Input bit 3. (TX CTCSS control)
23	INPUT PORT A. 8-bit Logic Input bit 4. (N/W address bit 0)
10	INPUT PORT A. 8-bit Logic Input bit 5. (N/W address bit 1)
22	INPUT PORT A. 8-bit Logic Input bit 6. (N/W address bit 2)
9	INPUT PORT A. 8-bit Logic Input bit 7. (N/W address bit 3)
21	INPUT PORT B. BCD Channel Select Units bit 0.
8	INPUT PORT B. BCD Channel Select Units bit 1.
20	INPUT PORT B. BCD Channel Select Units bit 2.
7	INPUT PORT B. BCD Channel Select Units bit 3.
19	INPUT PORT B. BCD Channel Select Tens bit 0.
6	INPUT PORT B. BCD Channel Select Tens bit 1.
18	INPUT PORT B. BCD Channel Select Tens bit 2.
5	INPUT PORT B. BCD Channel Select Tens bit 3.
17	OUTPUT PORT C. 8-bit Logic Output bit 7. \ Multiple CTCSS decode bit 7.
4	OUTPUT PORT C. 8-bit Logic Output bit 6. \ Multiple CTCSS decode bit 6.
16	OUTPUT PORT C. 8-bit Logic Output bit 5. \ Multiple CTCSS decode bit 5.
3	OUTPUT PORT C. 8-bit Logic Output bit 4. \ Multiple CTCSS decode bit 4.
15	OUTPUT PORT C. 8-bit Logic Output bit 3. \ Multiple CTCSS decode bit 3.
2	OUTPUT PORT C. 8-bit Logic Output bit 2. \ Multiple CTCSS decode bit 2.
14	OUTPUT PORT C. 8-bit Logic Output bit 1. \ Multiple CTCSS decode bit 1.
1	OUTPUT PORT C. 8-bit Logic Output bit 0. \ Multiple CTCSS decode bit 0.

Table 3 CN3 Connections

CN4 DB9 Male RS232 Connector

MX921 when option PCB T45 fitted provides RS232 serial port to the rear. Only 3 wires are required for the MX921 TXD, RXD and ground. The Rear RS232 feature is currently under development please refer to www.spectraeng.com.au for updates on firmware revision.

Pin	Function
3	Transmitted Data (TD)
2	Received Data (RD)
5	Signal Ground (SG)

Table 4 CN4 Connector Jumpers

CN5 DC Power Input

DC power is connected to the transceiver through this connector. The transceiver is fitted with a 3-pin male connector. For 50W transceivers pins 2 and 3 are used for the 12V DC pin 1 is unused. The power lead to the transceiver should be made from a gauge of wire suitable to ensure less than 0.5V drop at 10A for the required length of the lead.

PIN No	Function
1	Unused \Solar Panel input used in conjunction with S02 Option
2	Ground
3	+ 13.8VDC

Table 5 CN5 DC Power Input Connections

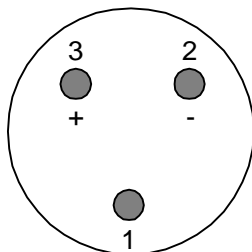

Figure 1 CN5 DC Input
(View from rear of MX921)

CN6 Simplex Relay

This is an N type connector, which acts as the RF I/O port for simplex operation. Optionally the RX input for duplex operation may use this port instead of the BNC port.

CN7 RX Input

This is a BNC connector used as the RX RF input.

CN8 TX Output

This is an N type connector used as the TX RF power output.

CN9 RJ45

The function depends upon which option board is fitted. A standard T45 option provides E/M leads with isolated line I/O.

A rectangular knock out section in the chassis provides for mounting of the connector & PCB should it be required to be retro fitted.

See Section Isolated E&M, RJ45 Socket for further information

TX Alignment

The MX921 has three main TX audio inputs. This provides the MX921 with a wide range of configurable options. These are balanced and Non-Balanced audio, DC FM or Wide band DC (DCFM WB). Please see Table 2 CN1 Connections for description of these inputs.

The option PCB has three manual potentiometers associated with the TX deviation on the option PCB. These are set by injecting the correct audio levels and adjusting the potentiometers. The transmitter modulating audio is to be connected to either the WB/DC-FM input or the TX VF input as described in the procedures.

The required nominal deviation is dependent on whether the radio is narrow, medium or wide. The following table lists the required level for each case:

Bandwidth	FM Deviation (kHz)
Narrow (12.5kHz spacing)	1.5
Wide (25kHz spacing)	3.0

Table 6 Nominal Deviation

TX VF input

The potentiometers RV4 & RV5 sets the TX VF line input level and nominal dev respectively. The transmitter modulating audio for this test is connected to the TX VF input. This input is located on the rear of the MX921, on the Line I/O connector pin 9 of the DB15F connector

Alignment Procedure:

1. PTT the transmitter.
2. Set the transmitter modulation frequency to 1 kHz, at nominal line input level (-10dBm is default level) injected in through the TX VF input.
3. Adjust TX VF gain RV4 to onset of compression. Insure JMP6 in position 1-2.
4. Set the transmitter modulation frequency to 1 kHz, at nominal line level (-10dBm) and adjust RV5 to obtain the nominal deviation.).
5. If audio bridge function is not used please adjust RV3 and RV1 to minimum Resistance (anti-clockwise). If bridge function is require please see Audio Bridge Function section for more information on adjusting RV3 and RV1.

TX Balanced VF Input

The potentiometer RV2 sets the TX Balanced VF line input level and nominal dev respectively. The transmitter modulating audio for this test is connected to the TX Balanced VF input. This input is located on the rear of the MX921, on the RJ45 I/O connector pin 3&6 of CN5.

Alignment Procedure:

Same as TX VF input except adjusted RV2 instead of RV4.

RX Alignment

The T45 option is fitted with a three RX line outputs. This consists of two unbalanced (DB15) and one balanced (RJ45). This provides an audio bridge function.

Please see Audio Bridge Function section for more information.

RX Line Outputs

RV6 sets the main RX Line output level for both balanced and unbalanced audios.

Procedure:

1. Using a 600ohm termination monitor RX line output level. This output is located on the rear of the MX921, on the Line I/O connector pin 15 of the DB15F CN1.
2. Set the receiver modulation frequency to 1 kHz and the FM deviation to nominal for the particular RF receive frequency of the test channel. Receive signal level -60dBm.
3. Adjust Line Output level RV6 to obtain nominal line output level (-10dBm is the default level).

Isolated E&M, RJ45 Socket

The T45 Option provides balanced and isolated VF I/O as well as isolated E (PTT) and M (Mute) leads, through the RJ45 Socket located on the rear of the radio. The option has been design to be compatible with Omitronics interface connections.

The E lead is opto isolated and may be asserted by applying a DC voltage between 5V and 48V with any polarity between CN5 Pins 1&2 (JMP1 in position 2-3).

Provision is also made to internally source the activation voltage (+12V DC) in which case the E lead is asserted by grounding CN9 Pin2 (JMP1 in position 1-2)

The M lead is relay isolated and the common and normally open contacts are brought out via CN5. If the internal +12V DC is being used as the activation voltage for the E lead (JMP3 in position 1-2) then the normally closed contact is also available at CN9 pin 8. The relay contacts are rated at 500mA.

Pin No RJ45	RJ45 Function
5	600ohm balanced RX VF leg a
4	600ohm balanced RX VF leg b
6	600ohm balanced TX VF leg a
3	600ohm balanced TX VF leg b
7	M Lead common
8	M Lead normally open
2	E Lead leg a/M lead normally closed
1	E Lead leg b

Table 7 CN9 RJ45 Pin outs.

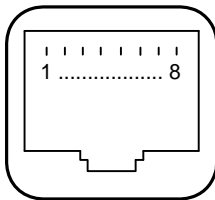

Figure 2 CN9 RJ45 Pin-out Detail
(View from Rear of MX800)

JMP	Factory Default setting
1	Position 2-3
2	Not fitted
3	Position 2-3
4	Not fitted

Table 8 Factory Default Jumper Setting

Audio Bridge Function

The option PCB provides three way four wire Audio Bridge function. This provides a cost effective solution for the combining and linking of repeaters, links and other audio sources to remote sites.

The three way bridge consists of the master radio (See figure SC010-1A below -Site A) which has the T45 option PCB fitted plus two other radios forming the links.

The audio bridge mode allows the master unit to work as a repeater and share its audio\E&M to two ports on the MX921 (DB15 & RJ45). The RJ45 provides balanced audio and E&M for one link bi-directional to the master unit. The DB15 provides audio and E&M for the second link bi-directional to the master unit.

Programming:

1. Connect MX921 to HyperTerminal.
2. Enter the build in menu system and select Option T45 system interface menu.
3. Then you will need to enable the bridge mode - Cross DB15/RJ45 E&M. *This provides Link to Link cross over. (Audio\E&M from one side of a link is connected to the other link radio.)*

Alignment Procedure:

Insure TX and RX alignments are performed as mentioned previous sections.

We now need to adjust the TX & RX Audio crossover from DB15 and RJ45 ports. This is done via RV3 and RV1.

1. Inject an audio signal, modulation at a frequency of 1 kHz, at nominal line input level (-10dBm is default level) injected in through the RJ45 input (pin 3&6).
2. Adjust Line Output level to DB15 (pin 3) via RV1, to obtain nominal line output level. (-10dBm is the default level)
3. Now Inject an audio signal, modulation at a frequency of 1 kHz, at nominal line input level (-10dBm is default level) injected in through the DB15 TX VF input (pin9).
4. Adjust Line Output level to RJ45 (pin 4&5) via RV3, to obtain nominal line output level. (-10dBm is the default level)

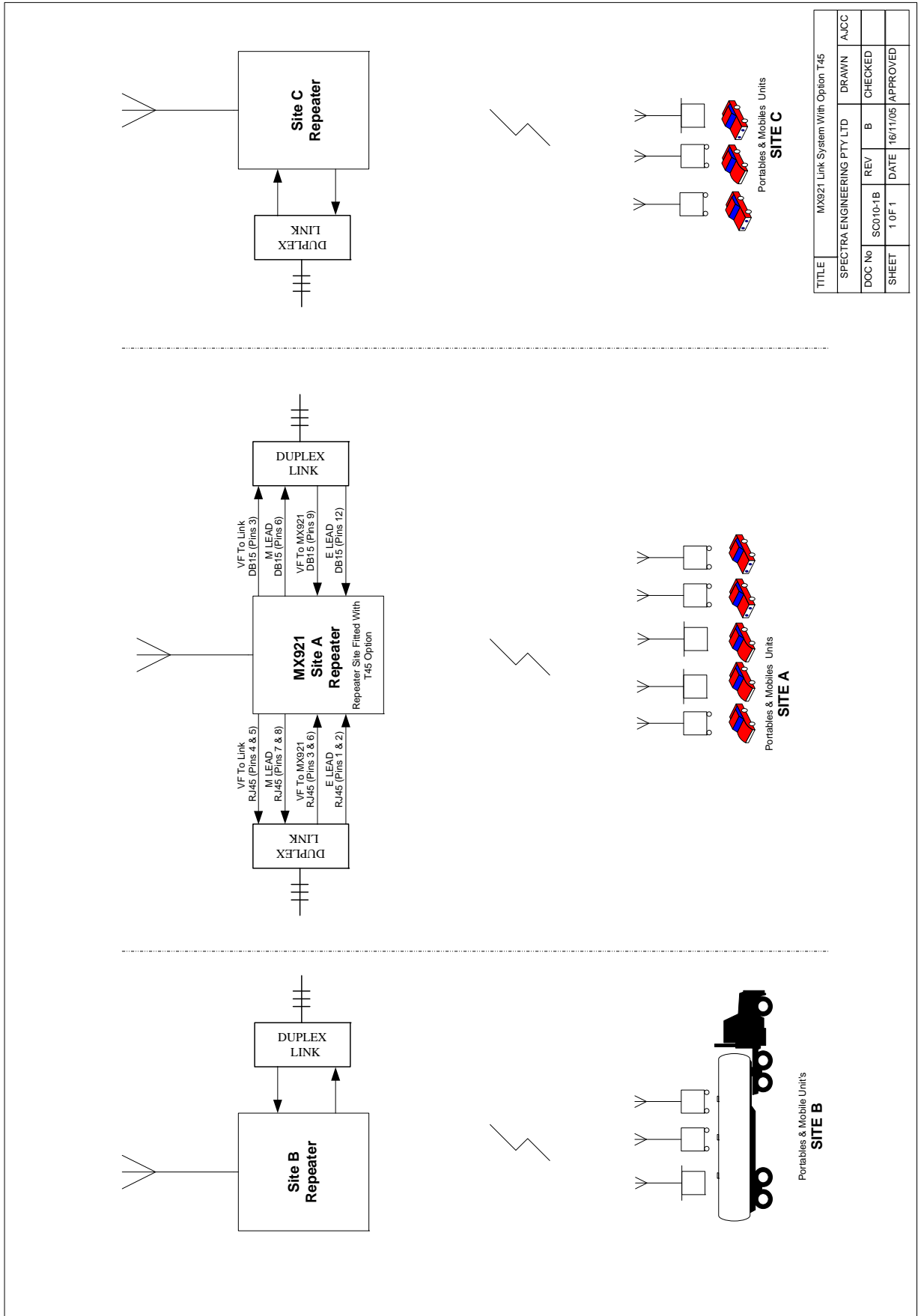



Spectra Engineering Pty Ltd

ABN 65 057 696 438

9 Trade Road

Malaga

Western Australia 6090

Tel: +61-8-92482755 Fax: +61-8-92482756

Email: info@spectraeng.com.au

Web: www.spectraeng.com.au

Revision 1.5 Oct 2010

In order to continually improve our products, Spectra Engineering Pty Ltd reserves the right to alter, without notice and at any time, the equipment and specifications described in this document.

All performance figures quoted are typical and are subject to normal manufacturing and service tolerances.

The purchaser is warned that statements made in this document may be inaccurate due to typographical or other errors or subsequent modifications of the product. While every care has been taken in the creation of this document, no warranty of accuracy or reliability is given, in any advice or information contained in this document. The responsibility for any loss or damage whatsoever arising in any way or any representation, act or omission whether express or implied (including responsibility to any person by reason of negligence) is not accepted by Spectra Engineering Pty Ltd or any director, officer, agent or employee of Spectra Engineering Pty Ltd.

Copyright © Spectra Engineering Pty Ltd 1997-2010.

This work is copyright. Other than as permitted by Law, no part of it may be reproduced, stored in a retrieval system or transmitted in any form or by any process without prior written permission.

FCC Interference Warning

Note: The equipment has been tested and found to comply with the limits for a class B digital device, pursuant to Part 15 of the FCC Rules. These limits are designed to provide reasonable protection against harmful interference when the equipment is operated in a commercial or residential environment. This equipment generates, uses and can radiate radio frequency energy. If not installed and used in accordance with this instruction manual, may cause harmful interference to radio communication.